

Bremse Br 11 / Brake Br 11

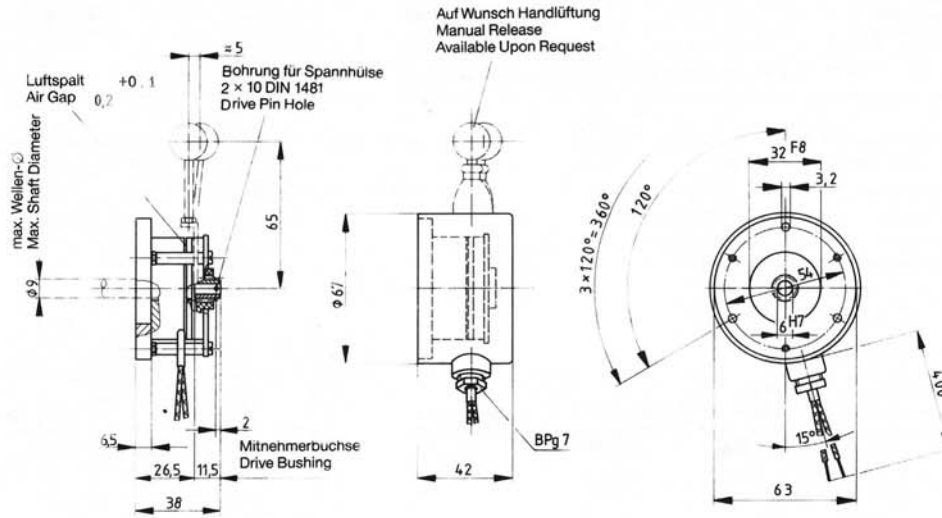

Schutzart IP 00
Protection Class IP 00
Protection IP00

Schutzart IP 54
Protection Class IP 54
Protection IP54

Flansch und Mitnehmerbuchse
Flange and Drive Bushing
Flasque et entraineur

Geeignet zum Anbau an Motoren / Mount Externally on Motors:
EM 70; KM 70; ME 70; MG 70;
EM 80; EM 3 80; KM 80; ME 80; MG 80.

Gewicht / Weight kg
0,3

Bremse Br 12 / Brake Br 12

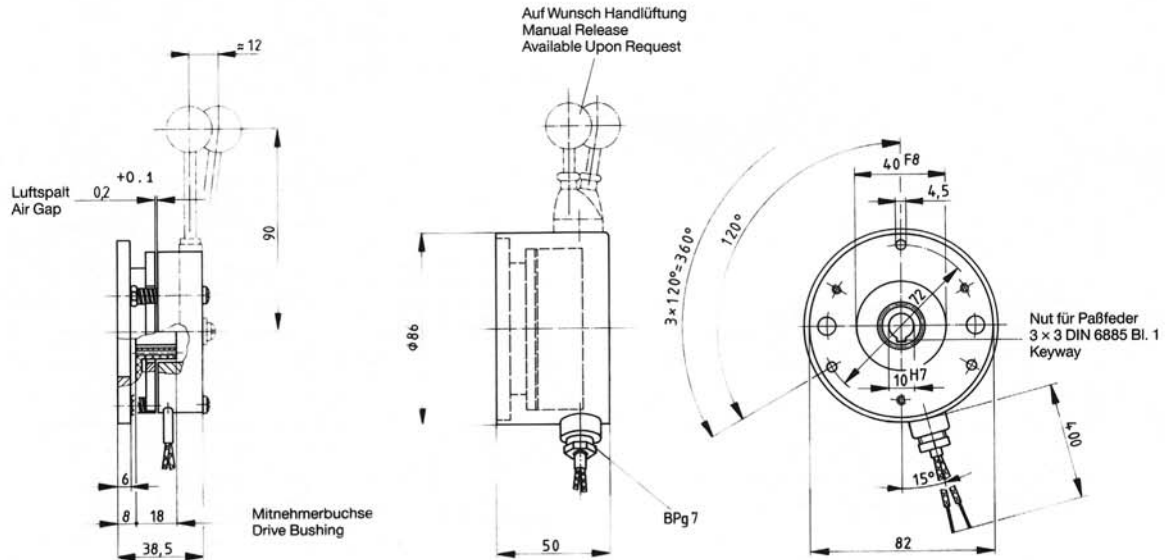

Schutzart IP 00
Protection Class IP 00
Protection IP00

Schutzart IP 54
Protection Class IP 54
Protection IP54

Flansch und Mitnehmerbuchse
Flange and Drive Bushing
Flasque et entraineur

Geeignet zum Anbau an Motoren / Mount Externally on Motors
EM 87; EM 3 87; KM 87; ME 90; MG 90;
EM 94; KM 94; ME 100; MG 100;
EM 120; KM 120; MG 120;
Geeignet zum Einbau in Motoren / Mount internally on Motors

PM 1 85

Gewicht / Weight kg
0,9

Maße ohne Toleranzangabe unverbindlich / Dimensions are in mm and are for reference only