

Dynamic. Precise. Powerful.

Silver Line[®] Stainless Steel Drives



GROSCHOPP 

Silver Line[®]

Stainless Steel Drives

The drive unit Silver Line[®] is a progressive development of the proven and tested Black Panther[®] and Vario Line, the difference being that it is made entirely of stainless steel. These stainless steel drives comprise electronically-commutated servo-motors, reducer gears and, optionally, integrated servo-controllers. The round housing, made of precision-machined V4A stainless steel, offers significant advantages in respect of corrosion resistance compared with conventional materials.

Screw connections and holes have disappeared below the housing surface. Silver Line[®] has been designed especially for high water protection, thus achieving by default protection class IP 65, optionally up to IP 69K. For this reason the drive unit is optimally suited for the industry sectors Foodstuffs, Pharmaceuticals, Chemistry or Medical Science.

General	Motor	Servo-controller
<ul style="list-style-type: none">Protection Class IP 65 / IP 67 / IP 69KStainless Steel: V4A 1.4401/ 04Applicable in extreme environmentsNo accumulation of suspended matter due to hygiene-conform design	<ul style="list-style-type: none">Brushless AC-servo-motorExtreme high power densityHigh positioning accuracyCompact-builtResolver, optical encoder or VOLKSSERVO[®] - encoder	<ul style="list-style-type: none">Discrete or in motor-housing integrated controller electronicsRevolution-, torque- or position-controllerPower supply 24 - 60 V DC or 230 V / 400 V ACInterface: analogue/digital IO and CAN-Bus (CANopen protocol)Optionally: RS232, Ethercat, ModBus, ProfiBus
Reducer gear	De-centralised drives:	
<ul style="list-style-type: none">Worm-gear VES 31 and VES 40Modulare structureLow noiseLubricant approved for use in foodstuffs industryInserting shaft optional	<ul style="list-style-type: none">Axially integrated solutionSeparate Bus-plug-makeSeparate 9 to 30 Volt DC control-voltage supplyPower voltage supply 24 – 60 Volt DCOutput 50 to 200 WattsIntegrated MPU	



**Customized version
with integrated electronic**

Strong Performance without Edges and Corners

Type	Rated power in Watts	Reducer-gear combination	Drive-torque Nm	Overall-length mm
ESK 48-60 NR	120	VES 31	Md max 9 Nm	243,5
ESK 65-60 NR	350	VES 31	Md max 9 Nm	250
ESK 65-60 NR	350	VES 40	Md max 45 Nm	298,5
ESK 80-80 NR	580	VES 40	Md max 45 Nm	321,5
ESK 65-60 NI	up to 200	VES 31	Md max 9 Nm	310

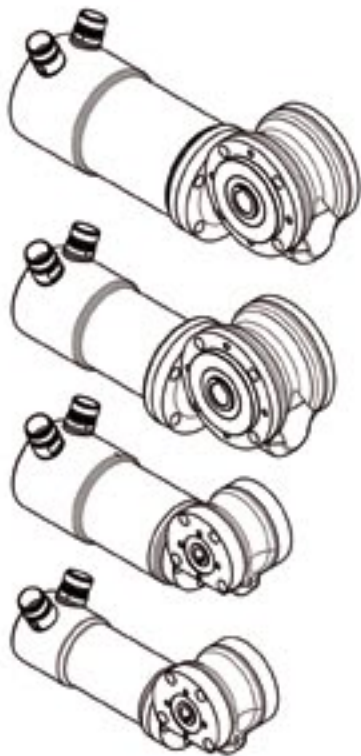

Talk to us.

GROSCHOPP 
Drives & More

Greefsallee 49
41749 Viersen
Phone: +49 (0) 21 62/3 74-0
Fax: +49 (0) 21 62/3 74-108
E-Mail: info@groschopp.de
www.groschopp.de

GROSCHOPP 