

# Drehstrom- / Asynchronmotoren 2- und 4-polig mit Lüfter AC- / Asynchronous motors 2- and 4-pole with fan

IGLC80 2p/ 4p | bis / up to 160 W

- Kühlung durch Lüfter
- Mehr Leistung aus geringerem Bauvolumen
- Motor nach Isolierstoffklasse F
- Schutzart IP54
- Betriebsart S1
- Phasenisolierung
- Auch mit IEC-Flansch (B14)
- Fan cooling
- More power despite reduced design space
- Motor insulation class F
- Protection IP54
- Operation mode S1
- Phase insulation
- Available with IEC flange (B14)

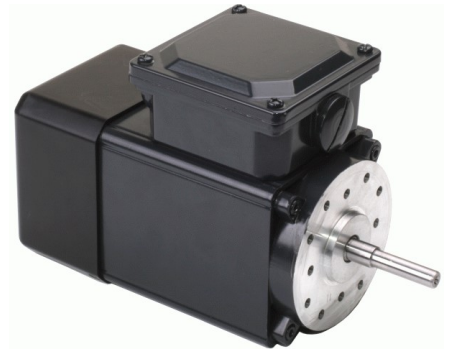

### Technische Daten / Data

		80-60 (2polig)		80-60 (4polig)	
Phasen Phases		3	1 Steinmetz	3	1 Steinmetz
Nennspannung Nominal voltage	V	400/230	230	400/230	230
Nennleistung Nominal power	W	180	125	120	105
Nenn Drehzahl Nominal speed	min <sup>-1</sup>	2600	2600	1330	1350
Nenn Drehmoment Nominal torque	Ncm	64	44	86	60
Nennstrom Nominal current	A	0,47 / 0,75	0,82	0,42 / 0,69	0,79
Aufnahmeleistung Input power	W	230	185	192	175
Rel. Anzugsmoment Rel. start torque	M <sub>Start</sub> /M	2,94	0,63	2,23	0,61
Rel. Kippmoment Rel. breakdown torque	M <sub>Kipp</sub> /M	2,63	1,74	2,15	1,41
Wirkungsgrad (100% / 75% / 50%) Efficiency (100% / 75% / 50%)	%	66,3 / 67,5 / 63,5	62,16	60,0 / 57,9 / 50,7	60
Leistungsfaktor Power factor	-	0,77	0,99	0,69	0,96
Kondensator Capacitor	µF	-	12	-	12
Gewicht Weight	kg	3,9	3,9	3,9	3,9
Wicklung Winding	-	1820601	1820601	1820701	1820701

Gültig bei Raumtemperatur 20°C / Ambient temperature of 20°C

### Kennlinien / Diagrams

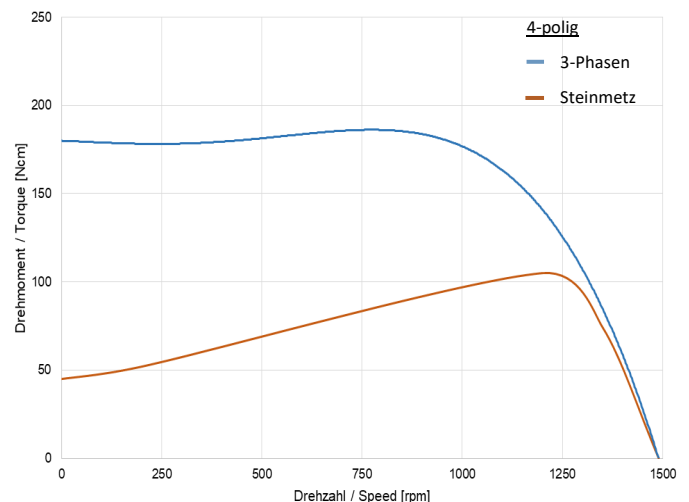
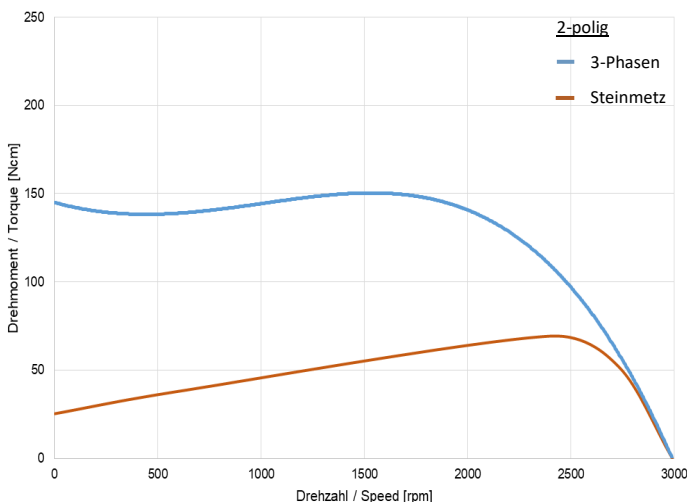

## Baureihe / Series - IGLC

Technische Zeichnung [mm] / Technical drawing [mm]

IGLC80 2p / 4p | bis / up to 160W

Für Getriebe SG80 / for gearbox SG80

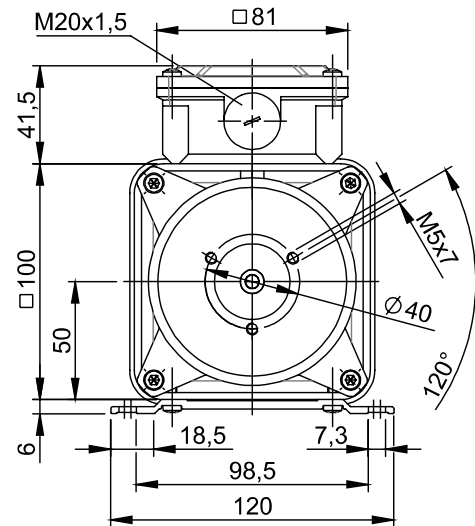
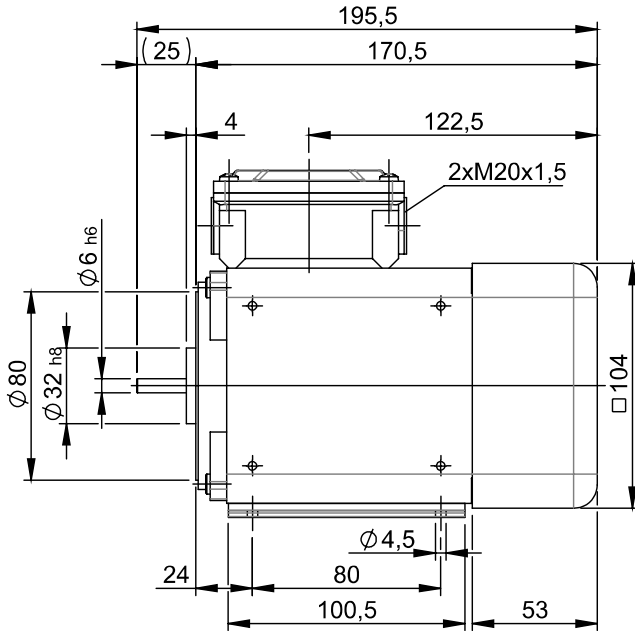

### 3-Phasen Anschluss

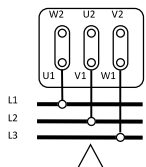
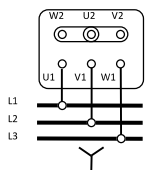

### 1-Phasen Anschluss

